



# INSTALLATION, OPERATION & MAINTENANCE MANUAL

## MODEL EB



ORBINOX SPAIN Pol.Ind. s/n-20270 ANOETA. Tel:+34 943 698030 Fax:+34 943 653066 e-mail:orbinox@orbinox.com

ORBINOX CANADA, ORBINOX USA, ORBINOX COMERCIAL, ORBINOX UK, ORBINOX FRANCE, ORBINOX GERMANY,  
ORBINOX INDIA, ORBINOX CHINA.

<u>INDEX</u>	<u>Page</u>
0.- Description .....	2
1.- Handling .....	2
2.- Installation .....	3
3.- Actuators .....	5
4.- Maintenance .....	5
4.1.- Gland packing and seal replacement .....	6
4.2.- Lubrication .....	7
5.- Storage .....	7
6.- Parts list & drawing .....	8

## 0.- DESCRIPTION

The EB model knife gate is a bi-directional valve and consequently it can be installed without considering the flow direction.

This valve is designed for general industrial service applications. The design of the body and seat assures non-clogging shut-off with suspended solids.

The EB valve complies with the following European directives:

- DIR 98/37/EC (machines)
- DIR 97/23/EC (PED) Fluid: Group 1 (b), 2 (Cat. I, mod.A)

It may also comply with the directive:

- DIR 94/9/EC (Explosive Atmospheres)



The EX valve may comply with the directive regarding equipment and protective systems for their use in explosive atmospheres. In these cases, the logotype  shall appear on the identification label of the valve. This label shows the exact classification of the zone where the valve can be used. The user will be liable for its use in any other zone.

This directive only applies in the following atmospheric conditions:

$$0,8 \text{ bar} \leq P \leq 1,2 \text{ bar}$$

$$-20^{\circ}\text{C} < T < 60^{\circ}\text{C}$$

Any increase in temperature due to frictional warmth is negligible, since the relative speed of the moving parts is extremely low.

The risk analysis associated to this directive does not take into account the fluid that goes through the valve, even when such fluid produces an explosive atmosphere. The user must take into account the risks that the fluid generates, such as:

- heating of the valve surface.
- generation of electrostatic charges caused by displacement of the fluid.
- shock waves caused by the installation (water hammer), internal crashes generated by the pellets or the risks due to foreign bodies susceptible of being present in the installation.

## 1.- HANDLING



When handling an Orbinox valve please pay attention to the following points:

- **Do NOT attach lifting gear to the valve actuators or gate guards.** They are not designed to bear the weight, and could easily be damaged.
- **Do NOT lift the valve by the valve bore.**  
This can cause damage to the seating surfaces and seals.

Ideally when using lifting gear to move an Orbinox valve, it should be supported by two or more eyebolts screwed into the tapped fixing holes in the valve body.

**SAFETY WARNING:**

- Check that the lifting gear is rated to carry the weight of the valve.
- Make sure the eyebolts have the same thread as the boltholes and that they are well secured.

During installation it is recommended to lift the valve via soft straps. These can be to the upper part of the valve body.

## 2.- INSTALLATION



To avoid personal injury or damage to property from the release of process fluid:

- Those in charge of handling and maintenance of the valve must be qualified and trained in valve operations.
- Use appropriate personal protection equipment (gloves, safety shoes, etc).
- Shut off all operating lines to the valve and place a warning sign.
- Isolate the valve completely from the process.
- Release process pressure.
- Drain the process fluid from the valve.
- According to **EN 13463-1 (15)**, during installation and maintenance operations, use hand tools (**non electric**) with Working Allowance.

Before installation, inspect the valve body and components for any damage that may have occurred during shipping or storage. Make sure the internal cavities within the valve body are clean. Inspect the pipeline and mating flanges, making sure the pipe is free of foreign material and that the flanges are clean.

The placement of a gasket between the valve and the counterflanges is not required, since the valve is equipped with "O"-rings in the flange face.

Special care should be taken to maintain the correct distance between the flanges and to ensure that they are parallel to the valve body. Incorrect alignment of the valve can cause deformations, which can lead to difficulties in operation.

The following table gives the maximum torque values for the valve fixing bolts. Also shown is the maximum depth (T) allowed for the tapped blind boltholes drilled into the valve body.

DN	50	65	80	100	125	150	200	250	300	350	400	450	500	600	700	800	900	1000
T (mm)	10	10	12	12	12	14	14	18	18	18	18	20	20	20	20	20	20	20
Kg.m	6	6	6	6	7	7	7	11	11	15	15	19	19	23	23	28	28	34

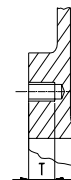

The valve can be mounted in any position with regard to the pipe. However, it is advisable to place it vertically in horizontal pipeline (A) if the installation allows it. (Please consult the technical department at Orbinox).

With larger diameters (> 300 mm), heavy actuators (pneumatic, electric, etc.), or with the valve installed horizontally (B) or at an angle (C) on a horizontal pipeline, the installation will require the construction of suitable supports. (See the following diagram and consult the technical department at Orbinox).

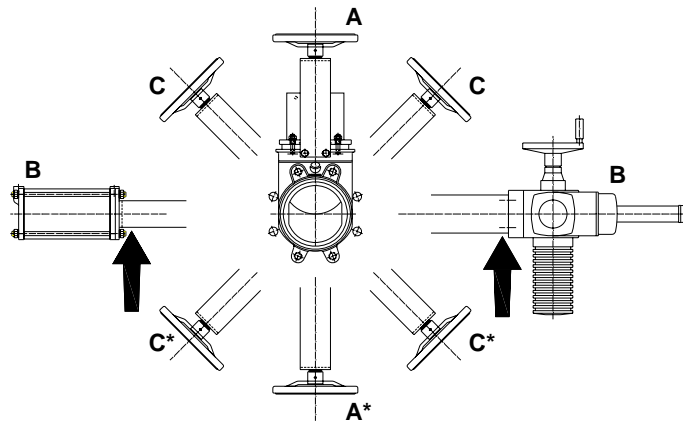

*\* For these positions please consult Orbinox.*

In vertical pipelines, the construction of suitable supports is always required (for further information please consult the technical department at Orbinox).

Once the valve is installed, test that the flanges have been fastened correctly and that all electrical and/or pneumatic connections have been properly made.



Where electric accessories are mounted on the valve (i.e. solenoid valves, electro-pneumatic positioners, etc.), or is in an ATEX zone, the corresponding earth connections must be made before it is put into operation.



The operation of automated valves is limited only with fitted gate covers.

First, operate the valve with no flow in the pipeline. Then test operation and valve seal with flow. It should be noted that the packing material might settle in shipping/storage, which can cause minor leakage. This can be remedied by tightening the gland (5) during installation.

The nuts shall be tightened gradually and crosswise until the leakage stops (see the next figure).

Check that there is no metal contact between the glandfollower (5) and the gate (2).

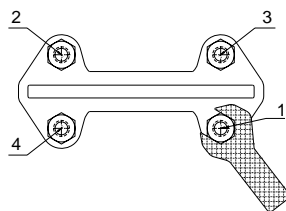

If the glandfollower nuts are pulled to hard, the force needed to operate the valve will increase, the valve function will be affected and the box packing lifetime will be shortened.

The table below shows the maximum torque value for tightening the glandfollower nuts.

DN	Torque (N.m)
50 - 100	20
125 - 200	30
250 - 1000	35

Once performance has been tested, the valve can be put into operation.



In an ATEX zone, the continuity between the body of the valve and the pipe must be checked (test in accordance with EN 12266-2 Standard, annex B, points B.2.2.2. and B.2.3.1).

It must also be verified that the pipe is connected to earth and that there is electrical conductivity between the two pipes (outlet/inlet).



Approximate weight of the handwheel-operated valve:

DN	50	65	80	100	125	150	200	250	300
Weight(Kg)	8	8,5	9,5	12	15	16,5	29	42	60

### 3.- ACTUATORS

#### 3.1.- Handwheel

To open the valve turn the handwheel (12) anticlockwise. To close turn the handwheel clockwise.

#### 3.2.- Lever

To operate the valve with this device, first loosen the locking clamp located on the top of the yoke (8). Then either open or close the valve by moving the lever in the desired direction. Finally, fix the position of the lever with the locking clamp.

#### 3.3.- Pneumatic

Valves are usually supplied with a double acting pneumatic actuator although, upon request, we can supply single-acting actuators. In either case the feed pressure can vary between 3,5 and 10 Kg/cm<sup>2</sup>. However, the size of the actuator for each valve has been designed for a feed pressure of 6 Kg/cm<sup>2</sup>.

It is essential for a good maintenance of the cylinder that air should be well dried, filtered and lubricated.

It is recommended to actuate the cylinder 3-4 times before the start up, once it is installed in the pipeline.

#### 3.4.- Electric actuator

Depending on the type or make of the electric actuator, specific instructions (i.e. a manufacturer's manual) will be supplied.

### 4.- MAINTENANCE

The valve must not undergo any modifications without a previous agreement with ORBINOX. ORBINOX shall not be liable for any damages that may arise due to the use of non original parts or components.



To avoid personal injury or damage to property from the release of process fluid:

- Those in charge of handling and maintenance of the valve must be qualified and trained in valve operations.
- Use appropriate personal protection equipment (gloves, safety shoes, etc.).
- Shut off all operating lines to the valve and place a warning sign.
- Isolate the valve completely from the process.
- Release process pressure.
- Drain the process fluid from the valve.
- According to **EN 13463-1 (15)**, during installation and maintenance operations, use hand tools (**non electric**) with Working Allowance.



In an ATEX zone, there may be electrostatic charges in the internal parts of the valve. These electrostatic charges, caused by the evacuation of the fluid, may entail a risk of explosion. It is the responsibility of the user to take extreme precautions to minimize this risk.



Safety in an ATEX zone:

- The maintenance personnel must be made fully aware of the risks of explosion, and it is advisable that they receive specific training regarding ATEX.
- Should the fluid transported create an internal explosive atmosphere, the user must check periodically the correct water-tightness of the installation
- Clean the valve periodically to prevent dust accumulation.
- Assembly at the end of the line is not allowed.
- Avoid repainting the products supplied.

The only maintenance required is to change the gland packing (4) and the seal (3).  
The life of these elements will depend on the working conditions of the valve such as: pressure, temperature, abrasion, chemical action, number of operations, etc.

4.1. - Replacement of the gland packing (4) and the seal (3):

- 1) Depressurise the circuit and place the valve in close position.
- 2) Remove the gate guards (for automatically actuated valves only).
- 3) - Non rising stem valves. Photo 1: Release the stem nut (7) from the gate (2).  
- Rising stem valves. Photo 2: Release the spindle or stem (6) from the gate (2).



Photo 1

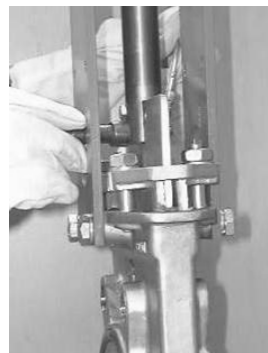

Photo 2

- 4) Loosen the screws of the yoke (8) and remove it (without loosening the actuator).
- 5) Loosen the nuts of the gland follower (5) and remove it. (Photo 3)
- 6) Remove the old packing lines (4), gate (2) and the old seal (3) to clean the stuffing box.
- 7) Insert the new seal (3) and the cleaned gate (2).
- 8) Once the necessary new packing lines (4) have been inserted, proceed with a steady initial tightening of the gland follower (5). (Photo 3)
- 9) Place the yoke (8) (with the actuator) and screw it.
- 10) Fix the stem nut (7) to the gate (2) (Non rising stem valves. Photo 1) or fix the stem (6) to the gate (2) (Rising stem valves. Photo 2).
- 11) Remount the gate guards (for automatically actuated valves only).
- 12) Carry out some operations with a loaded circuit and then re-tighten the gland follower (5) to prevent leakage.



Photo 3

<b>MODEL</b>	<b>EB</b>
--------------	-----------



#### 4.2.- Lubrication:

Lubricate the stem every 30 days with a calcium-based grease with the following characteristics: highly water resistant, low ash content, and excellent adherence.



After maintenance, and in an ATEX zone, it is obligatory to verify the electrical continuity between the pipe and the different valve components, such as the body, the gate, the supports,... (test in accordance with EN 12266-2 Standard, annex B, points B.2.2.2. and B.2.3.1).

## 5.- STORAGE

For long periods it is recommended to store the valves in a well-ventilated room. Valves should not be exposed to temperatures higher than 30°C, as some soft seal materials can be damaged when exposed to higher temperatures.

If outdoor storage cannot be avoided, cover the valve and protect it from sources of heat or direct sunlight. Provide good ventilation to avoid moisture.

## 6.- PARTS LIST &amp; DRAWING

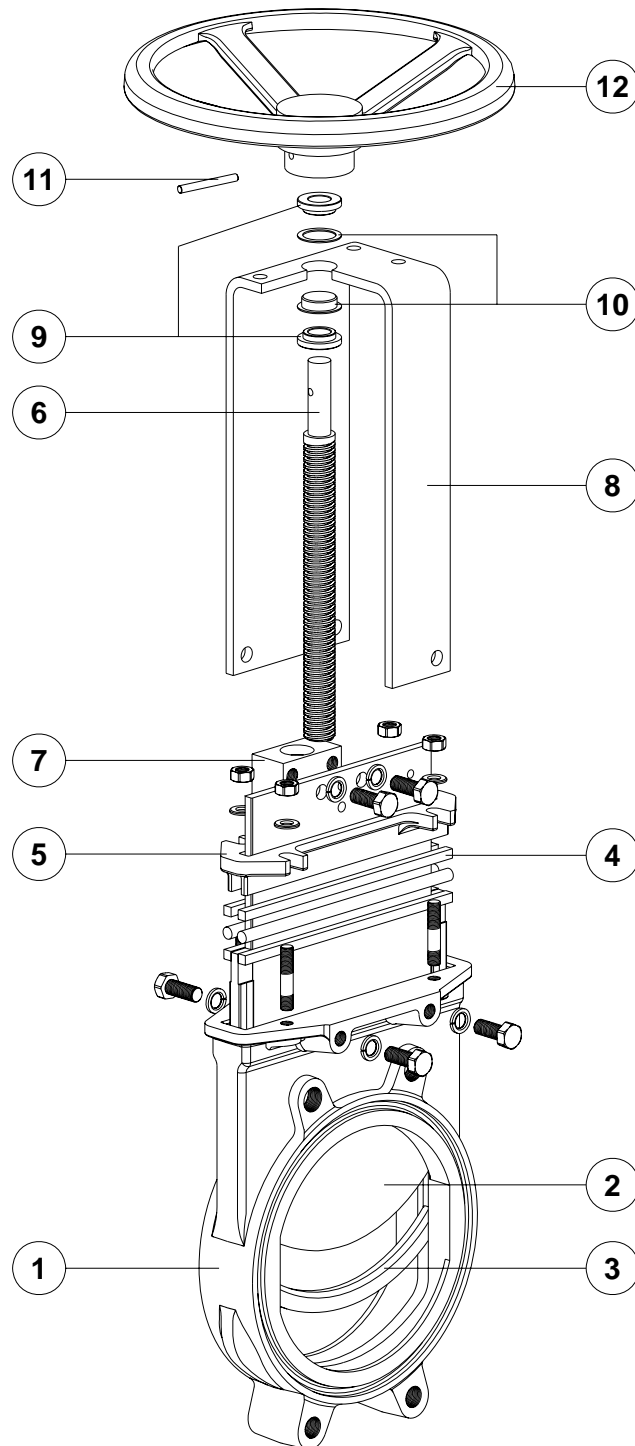

- |                    |                              |
|--------------------|------------------------------|
| 1.- BODY           | 7.- STEM NUT                 |
| 2.- GATE           | 8.- YOKE                     |
| 3.- SEAL           | 9.- BRASS COLLARS            |
| 4.- PACKING LINE   | 10.- NYLON COLLAR AND WASHER |
| 5.- GLAND FOLLOWER | 11.- PIN                     |
| 6.- STEM           | 12.- HANDWHEEL               |